

CT THERMISTOR

The CT thermistor is a thermal sensor in a DO35 package. Similar to the BT thermistor, it is highly reliable and offers a wide operating range of -50°C to (150°C) 250°C . It is primarily used in home electric appliances and features a competitive price for full-automated manufacturing system.

Part number

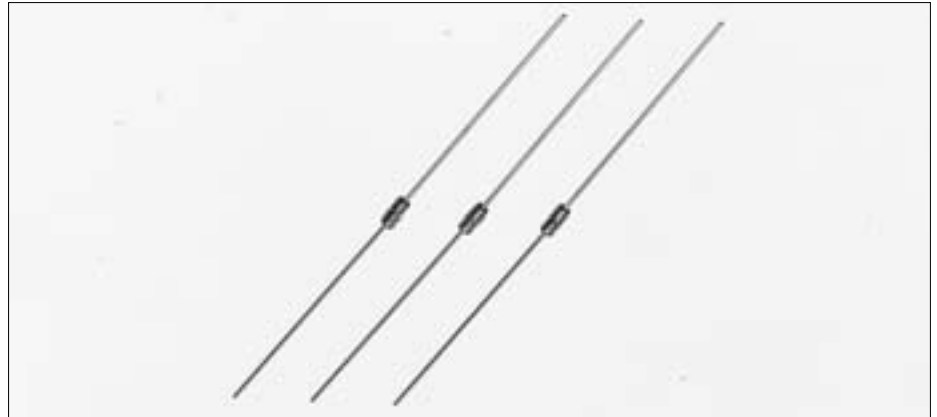
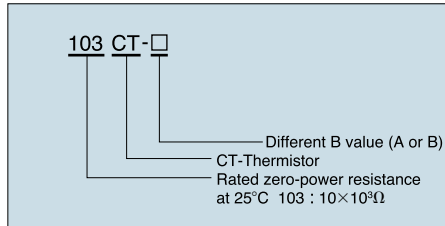

Dimensions

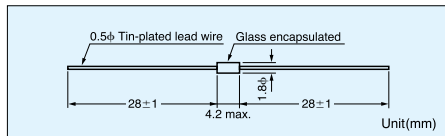

To allow automatic insertion, this product can be taped.

Taping Specification

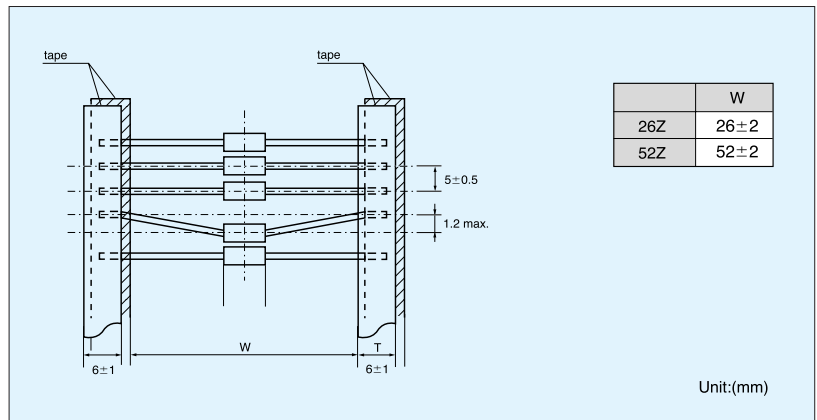

Specifications

Part No.	Rated zero-power resistance			temperature ($^{\circ}\text{C}$)	B value*2	Dissipation factor ($\text{mW}/^{\circ}\text{C}$) Approx.	Thermal time constant(s)*3 Approx.	Rated Electricity mW at 25°C	Category temp. range($^{\circ}\text{C}$)	Lead wire	Packing Method
	temperature*1 ($^{\circ}\text{C}$)	resistance	tolerance								
252CT-4	25	2.50k Ω	$\pm 5\%$	25/85	3670K $\pm 2\%$	2.1	10~20	10.5	-50~+250	Nickel plate	Individually packed
512CT-4		5.10k Ω			3200K $\pm 2\%$						
562CT-4		5.60k Ω			3200K $\pm 2\%$						
912CT-4		9.10k Ω			3270K $\pm 2\%$						
103CT-4		10.0k Ω			3270K $\pm 2\%$						
113CT-4		11.0k Ω			3270K $\pm 2\%$						
203CT-4		20.0k Ω			3410K $\pm 2\%$						
473CT-4		47.0k Ω			3610K $\pm 2\%$						
513CT-4		51.0k Ω			3610K $\pm 2\%$						
563CT-4		56.0k Ω			3610K $\pm 2\%$						
104CT-4		100k Ω			3450K $\pm 2\%$						
204CT-4		200k Ω			3500K $\pm 2\%$						
252CT-20218		0			7.881k Ω						
103CT-11005	25	10.0k Ω	$\pm 2\%$	25/50	3680K $\pm 2\%$	-30~+150	26mm taping				
103CT-21048	25	10.0k Ω	$\pm 3\%$	25/85	4100K $\pm 2\%$	-40~+150	Individual				
103CT-01006	25	10.0k Ω	$\pm 5\%$	25/85	3900K $\pm 2\%$	-30~+150	26mm taping				
103CT-20217	0	30.0k Ω	$\pm 3\%$	25/50	3434K $\pm 2\%$		52mm taping				
503CT-91027	50	19.727k Ω	$\pm 2.5\%$	25/85	3992K $\pm 2\%$	-40~+150	26mm taping				
104CT-90113	25	100.0k Ω	$\pm 5\%$	25/85	4070K $\pm 2\%$		52mm taping				
503CT-90083	85	5.911k Ω	$\pm 3\%$	25/85	3800K $\pm 2\%$	-40~+250	Nickel plate	Individual			

*1 Rated zero power resistance at each temperature.

*2 B value : determined by rated zero-power resistance at each temperature.

*3 Time when thermistor reaches 63.2% of the temperature difference. The value is measured in the air.