

CHIP TYPE THERMISTOR

KT THERMISTOR

Chip thermistors are specially processed, highly reliable thermistors.

They can be face-bonded to act as thermal compensators for ICs and they are manufactured in sizes down to 1 square mm, they can also be used to detect temperature with relatively small time constants.

KT-type Part number

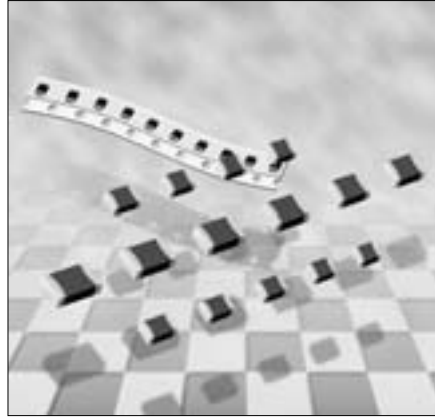
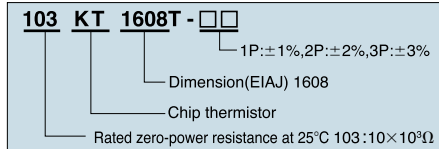

Precautions

- Do not expose the thermistors to high soldering heat for more than specified time. (260°C for not longer than 10s is recommended)

Dimensions

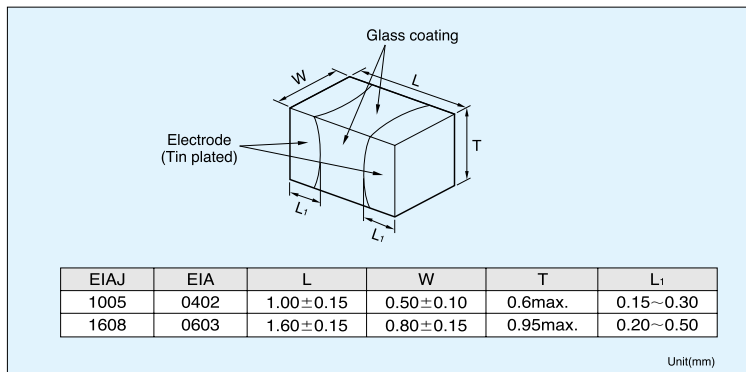

Reflow soldering profile

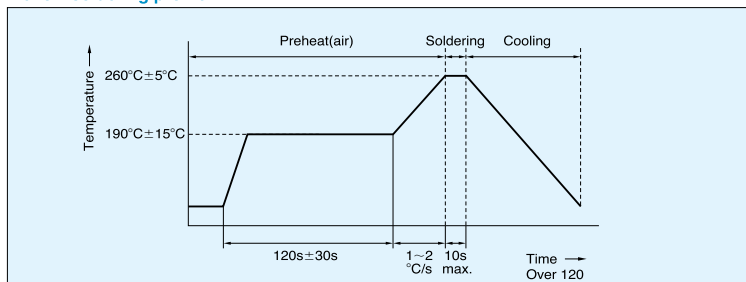

Taping (1608 type)

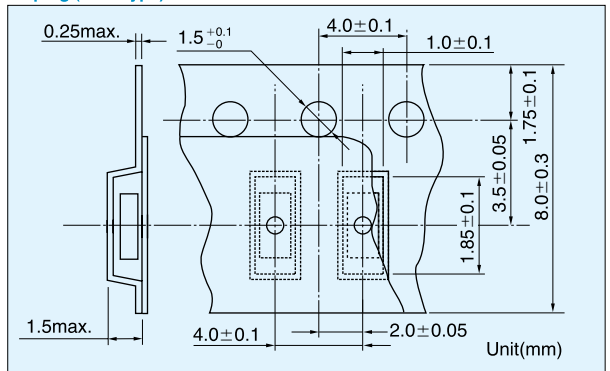

Minimum quantity:4000pcs/reel

(1005 type)

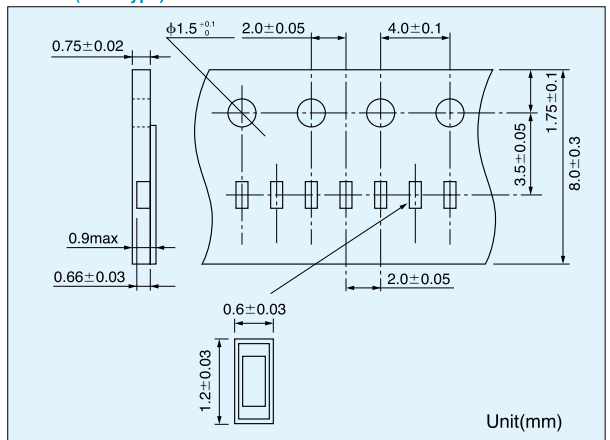

Minimum quantity:10000pcs/reel

Specifications

Part No.	R ₂₅ ^{*1}	B value ^{*2}	Dissipation factor (mW/°C) Approx.	Thermal time constant(s) ^{*3} Approx.	Rated maximum power dissipation (at 25°C)(mW)	Category temp. range(°C)
103KT1608T	10kΩ	3435K±1%	0.9	5.0	4.5	-40~+125
503KT1608T	50kΩ	4055K±1%				
104KT1608T	100kΩ	4390K±1%				
103KT1005T	10kΩ	3435K±1%	0.7	2.2	3.5	

*1 R₂₅: Rated zero-power resistance value at 25°C.

*2 B value: determined by rated zero-power resistance at 25°C and 85°C.

*3 Time when thermistor temperature reaches 63.2% of the temperature difference. The value is measured in the air. Other resistance is available, please ask.